

Лестницы и стремянки

НЧП-1690, P-280;150
0.334/-

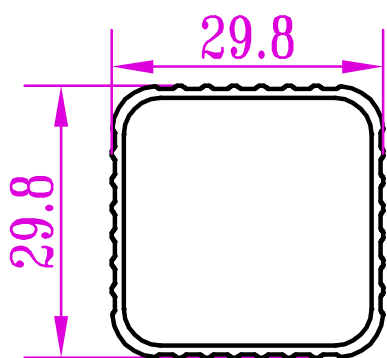

НЧП-1691, P-280;150
0.439/-

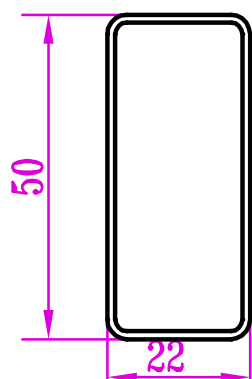

НЧП-1692, P-280;150
0.519/-

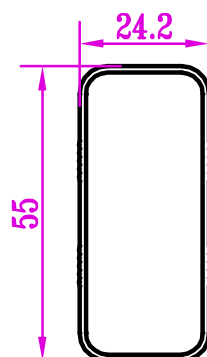

НЧП-1694, P-150;180;146
0.662/-

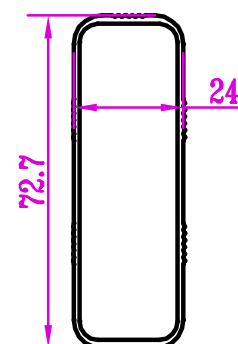

НЧП-1695, P-280;188;150;146
0.532/-

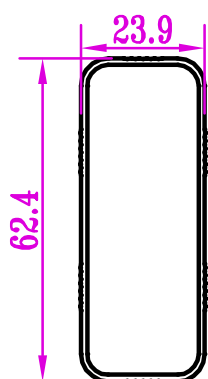

НЧП-2556, P-150
0.574/-

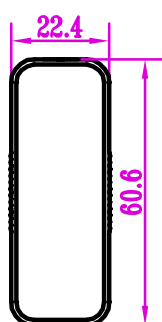

НЧП-3477, P-150;146
0.294/-

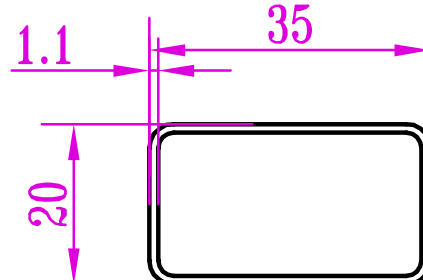

НЧП-3478, P-150
0.245/-

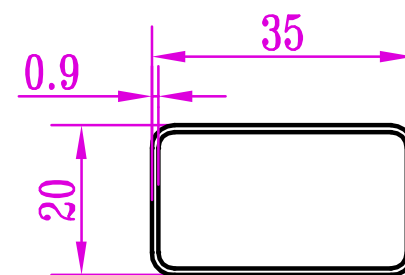

НЧП-3568, P-150
0.303/-

НЧП-3569, P-150
0.420/-

НЧП-3570, P-150
0.367/-

НЧП-3576, P-150
0.316/-

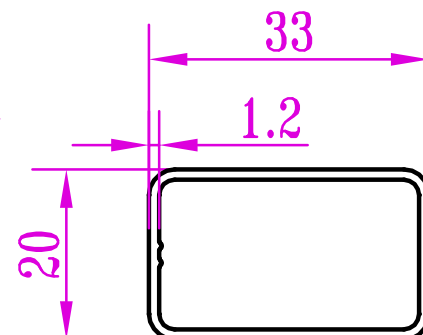
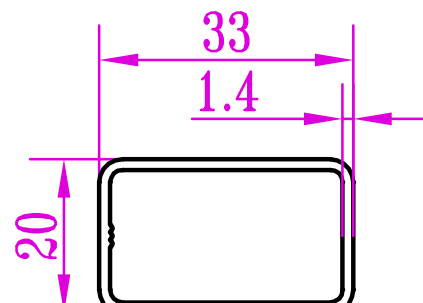
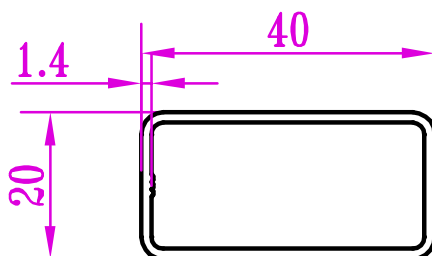
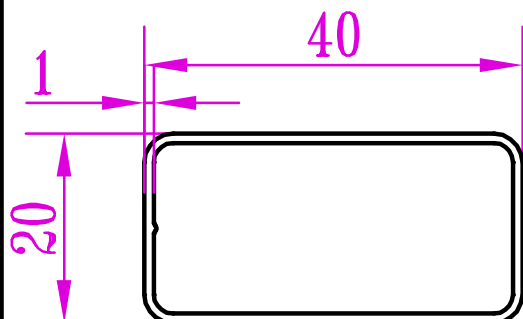

НЧП-3648, P-150;146
0.802/-

НЧП-4036, P-188
0.358/-

НЧП-4038, P-188
0.452/-

НЧП-4039, P-188
0.580/-

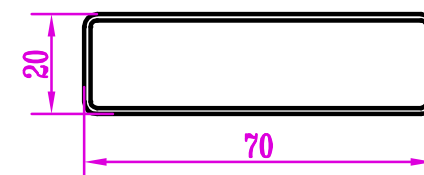
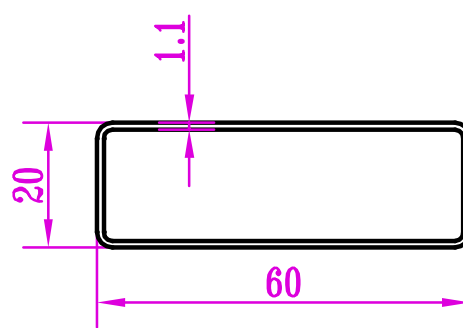
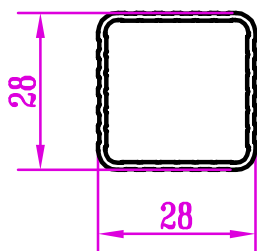
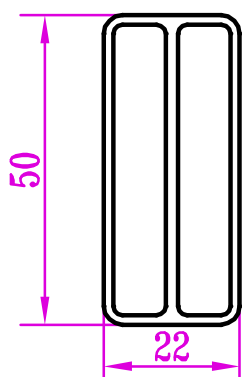

НЧП-4089, P-150
0.266/-

НЧП-4090, P-150
0.363/-

НЧП-4091, P-150
0.304/-

НЧП-4092, P-146
0.448/-

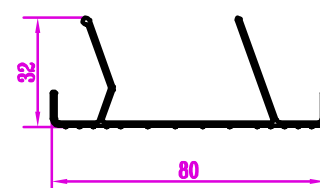
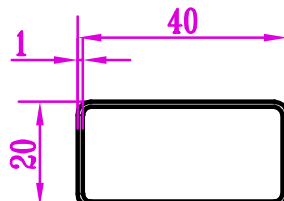
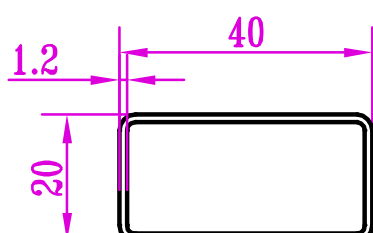
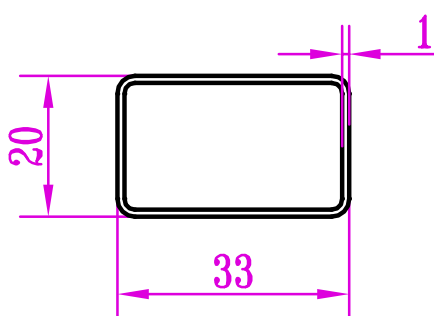

НЧП-4294, P-146
0.497/-

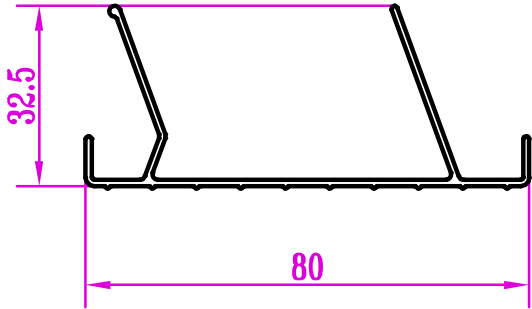

НЧП-4302, P-150
0.303/-

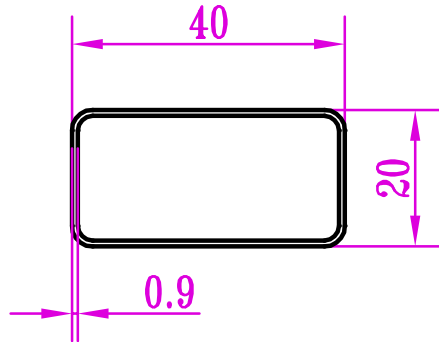

НЧП-4304, P-150
0.380/-

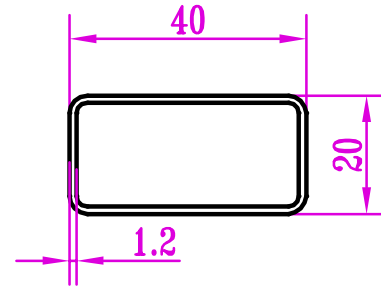

НЧП-4312, P-280;150
0.422/-

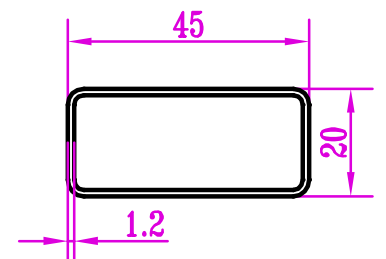

НЧП-4318, P-146
0.497/-

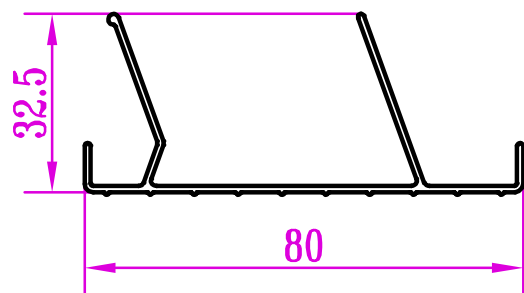

НЧП-4486, P-146
0.666/-

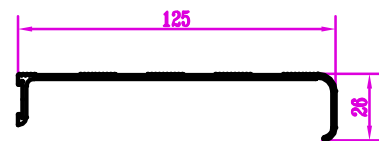

НЧП-4487, P-146
0.671/-

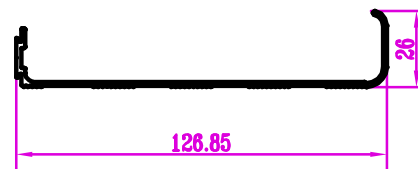

НЧП-4661, P-150
0.471/-

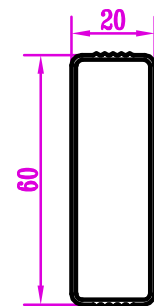

НЧП-4662, P-188
0.556/-

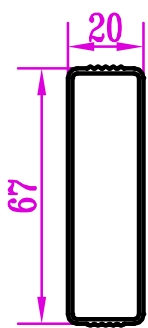

НЧП-4663, P-146
0.758/-

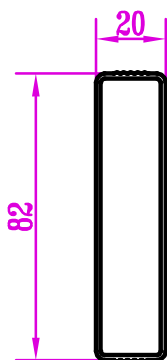

НЧП-4710, P-280
2.349

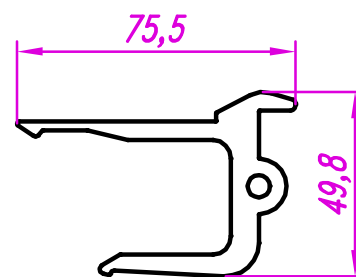

НЧП-4711, P-280
2.076/-

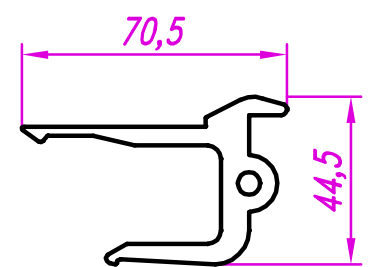

НЧП-4712, P-150
0.294/-

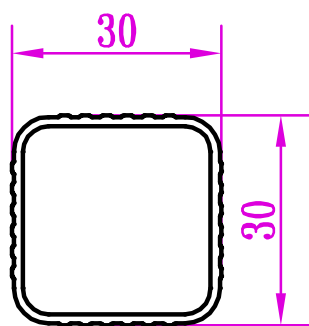

НЧП-4713, P-150
0.329/-

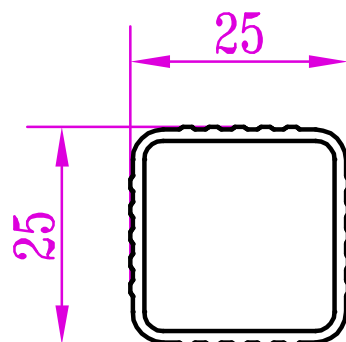

НЧП-4714, P-150
0.408/-

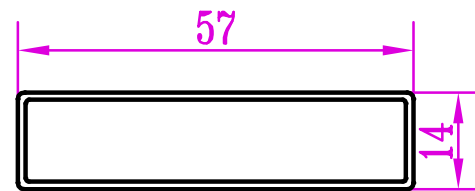

НЧП-4715, P-146
0.749/-

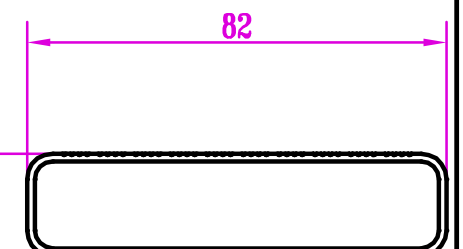

НЧП-4716, P-150;188
0.533/-

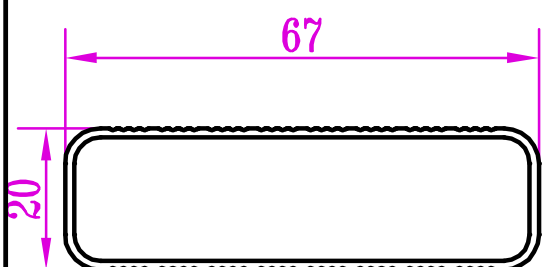

НЧП-4717, P-150
0.411/-

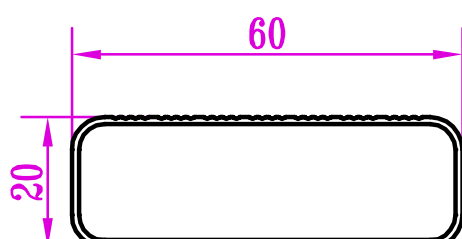

НЧП-4718, P-280
4.115/-

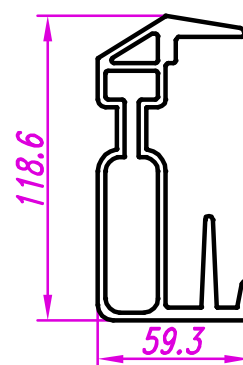

НЧП-4719, P-280
4.335/-

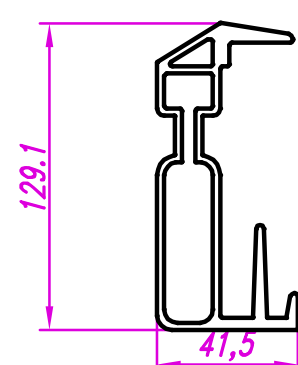

Лестницы и стремянки

НЧП-4720, P-280
4.788/-

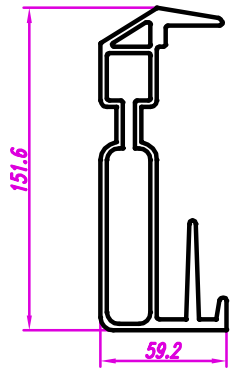

НЧП-4852, P-146
0.484/-

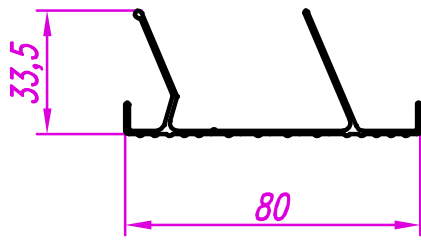

НЧП-4861, P-150
0.362/-

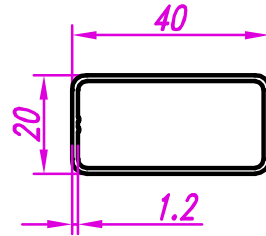

НЧП-4863, P-150
0.249/-

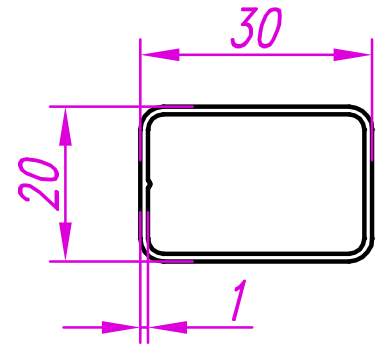

НЧП-4864, P-150;280
0.301/-

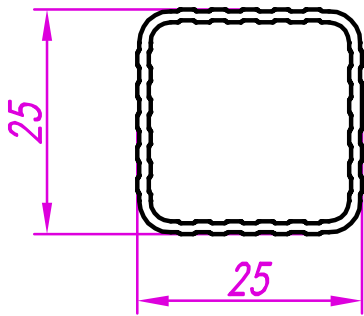

НЧП-4865, P-150
0.494/-

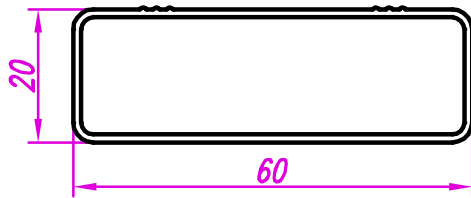

НЧП-4880, P-150
0.305/-

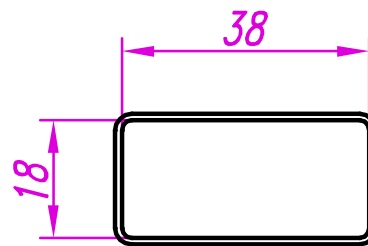

НЧП-4884, P-146;200
0.696/-

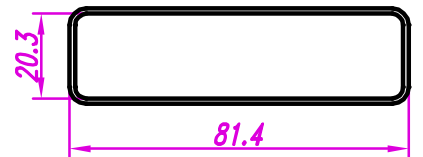

НЧП-4885, P-146
0.808/-

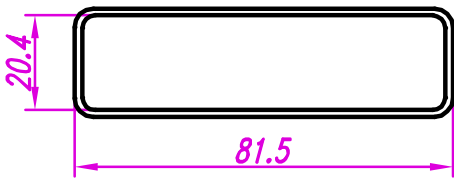

НЧП-4886, P-150
0.569/-

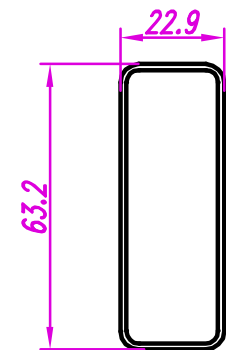

НЧП-4887, P-150
0.505/-

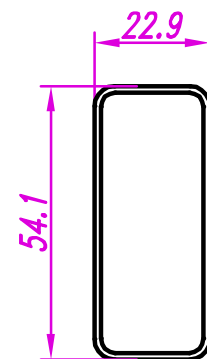

НЧП-4888, P-150;146
0.487/-

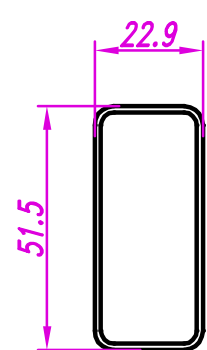

НЧП-4912, P-150
0.315/-

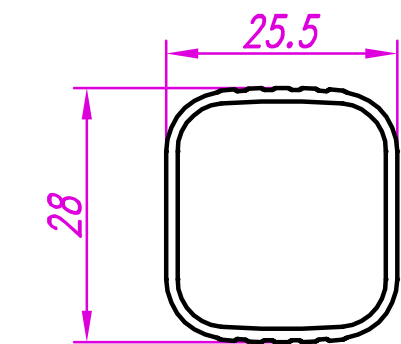

НЧП-5004, P-146
0.222/-

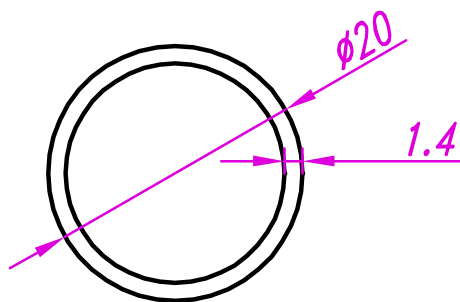

НЧП-5075, P-150
0.303/-

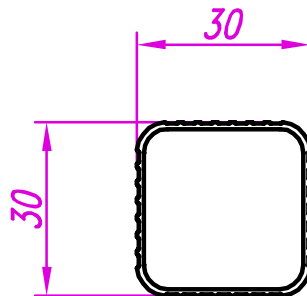

НЧП-5076, P-150
0.540/-

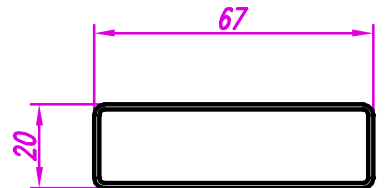

НЧП-5077, P-150
0.454/-

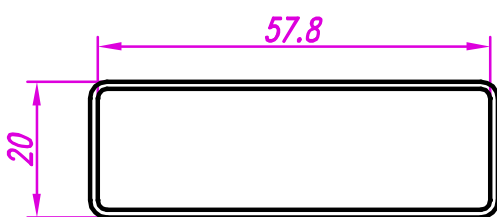

НЧП-5078, P-150
0.465/-

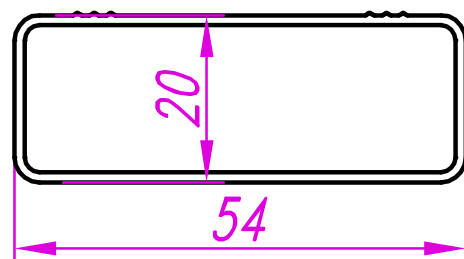

НЧП-5079, P-150
0.581/-

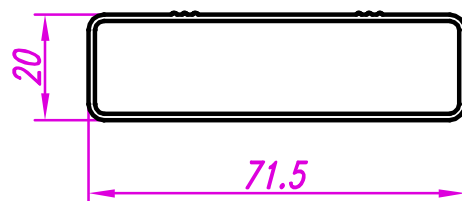

НЧП-5088, P-150
0.273/-

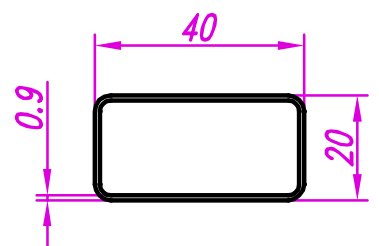

НЧП-5103, P-150
0.741/-

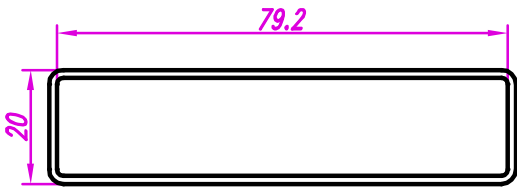

НЧП-5135, P-280
5.586/-

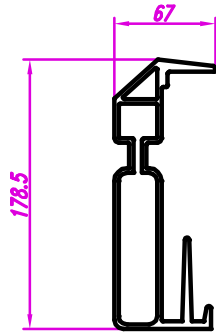

НЧП-5136, P-150
0.994/-

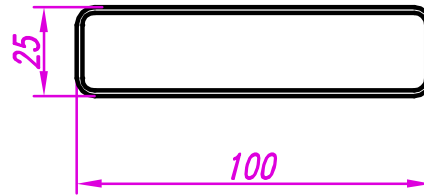

НЧП-5137, P-150
0.586/-

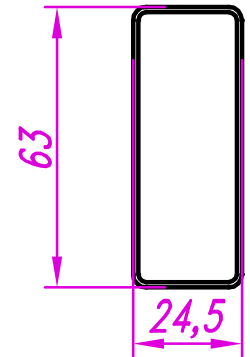

НЧП-5152, P-150
0.239/-

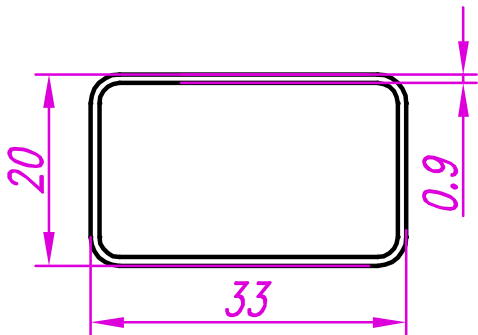

НЧП-5186, P-150
0.267/-

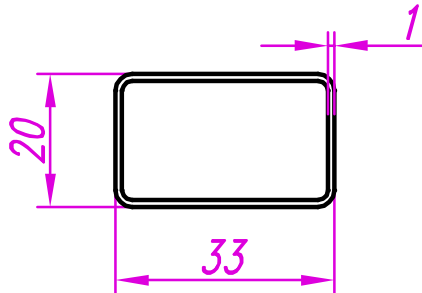

НЧП-5187, P-150
0.291/-

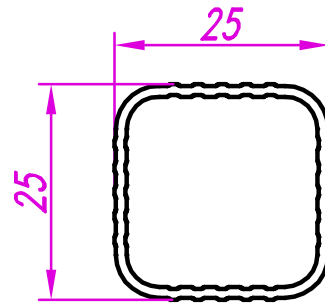

НЧП-5188, P-150
0.461/-

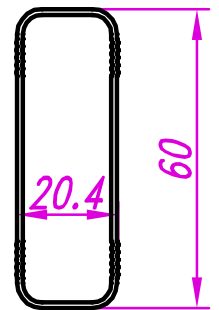

НЧП-5189, P-150
0.559/-

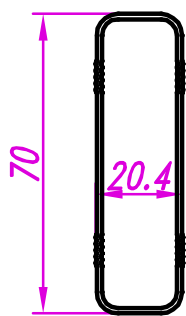

НЧП-5190, P-146
0.734/-

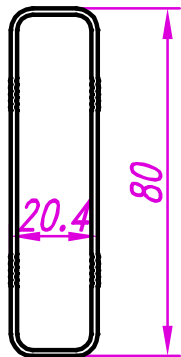

НЧП-5206, P-146
0.797/-

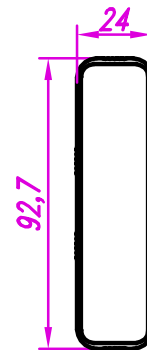

НЧП-5275, P-150
0.445/-

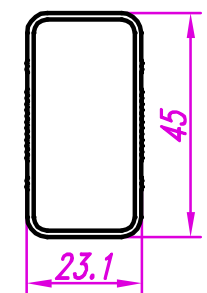

НЧП-5279, P-150
0.588/-

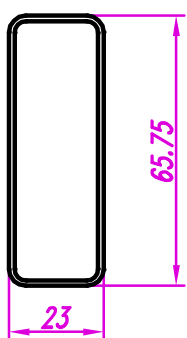

НЧП-5284, P-150
0.851/-

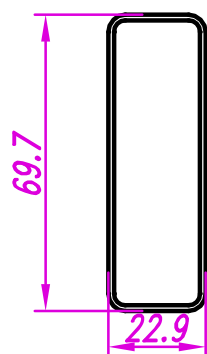

НЧП-5348, P-150
0.251/-

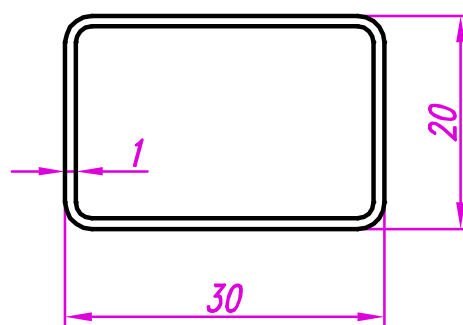

НЧП-5349, P-146
0.540/-

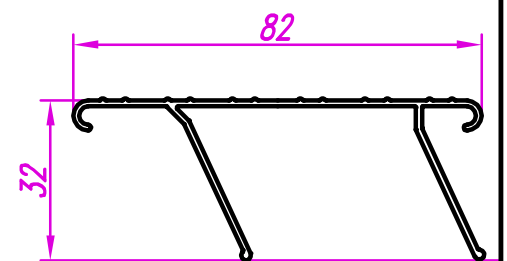

НЧП-5484, P-150
0.851/-

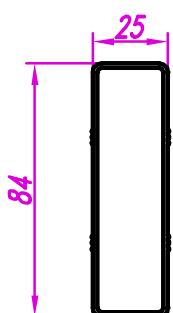

НЧП-5485, P-150
0.591/-

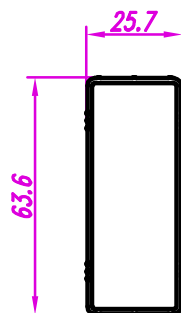

НЧП-5570, P-
1.023/-

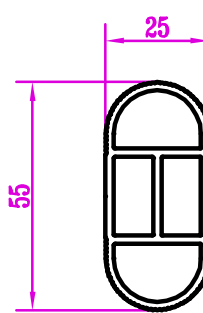

НЧП-5582, P-
0.332/-

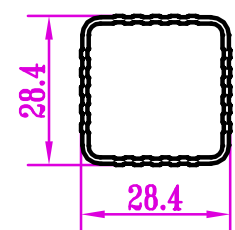

НЧП-5625, P-146
0.526/-

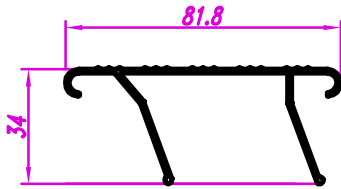

НЧП-5626, P-150
0.257/-

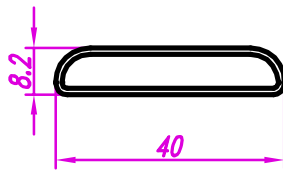

НЧП-5628, P-
0.642/-

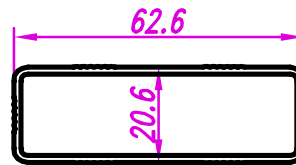

НЧП-5629, P-
0.510/-

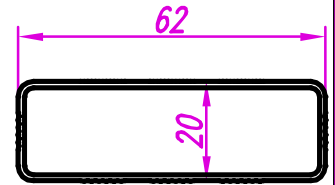

НЧП-5630, P-
0.526/-

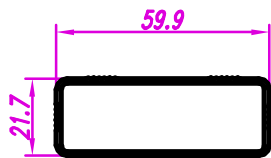

НЧП-2498, P-146
0.912/-



НЧП-2499, P-150
0.249/-

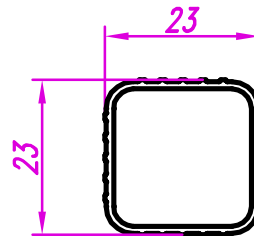

НЧП-4005, P-150;188
0.338/-

